

RG Series

OGI Handheld Camera

User Manual V1.0.0

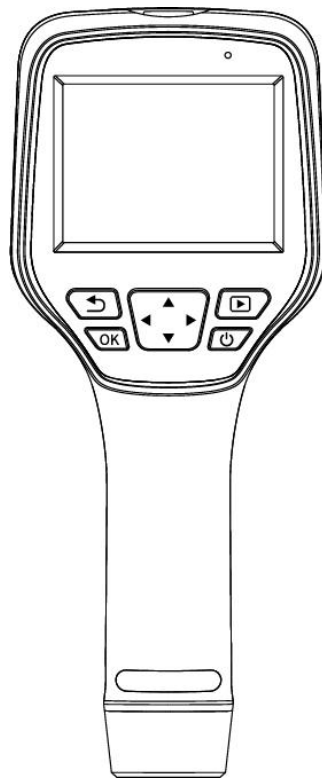

Table of Contents

1.Safety Information	1
2.Product Introduction	2
2.1 Camera	2
2.2 Buttons	3
2.3 Connector and Memory Card	4
3.Quick Start Guide	4
4.User Interface	5
5.Operation Instruction	6
5.1 Charging	6
5.1.1 Charge with a Power Adapter	6
5.1.2 Charge with a Computer	6
5.1.3 Charge with a Charging Base	6
5.2 Power On/Off	6
5.3 Focus Adjustment	6
5.4 Image/Video Capture	7
5.5 View Photos/Videos	7
5.6 Set Gas Detection Mode	9
5.7 Measurement Parameters	9
5.8 Set Measurement Mode	10
5.9 Image Mode	10
5.9.1 Image Mode Introduction	10
5.9.2 Setting Steps	10
5.10 Change Color Palettes	11
5.11 Non-uniformity Correction	11
5.11.1 Non-uniformity Correction Introduction	11
5.11.2 Non-uniformity Correction Operations	11
5.12 Contrast Adjustment	11
5.13 Digital Zoom	12
5.14 Other Settings	12
5.14.1 Temperature Measurement Mode	13
5.14.2 Above/Below Temperature Alarm	13
5.14.3 Wi-Fi Settings	14
5.14.4 Photo Settings	14
5.14.5 Dual-spectrum Alignment	15
5.14.6 Automatic Power-off	16
5.14.7 System Settings	16

6. Technical Specifications 17

 6.1 RG600F 17

 6.2 RG600C 19

7. Dimensions 21

8. Cleaning Thermal Camera 22

 8.1 Cleaning Camera Housing, Cables and Other Items 22

 8.2 Cleaning Infrared Lens 22

Appendix A Emissivity of Commonly Used Materials 23

1.Safety Information



WARNING

Make sure you read all applicable Material Safety Data Sheets (SDS) and warning labels on containers before you use a liquid. The liquids can be dangerous. Injury to persons can occur.

Do not place the product in environments with temperatures higher than 60°C or lower than -20°C.

The device operates within a relative humidity range of 10% to 95%, non-condensing.

Do not disassemble or modify the thermal camera without authorization.



CAUTION

Do not use the product under conditions that doesn ' t match the environmental requirements. For specific use environment requirements, see the product parameter table.

Do not apply solvents or equivalent liquids to the camera, the cables, or other items.

Be careful when you clean the infrared lenses. The lens has an anti-reflective coating which is easily damaged. Damage to the infrared lens can occur with too much force or cleaning with rough objects such as tissues.

No matter there is a lens cover or not, do not point the infrared thermal camera towards strong light or equipment with laser radiation. This will affect the accuracy of the thermal camera and even damage the detector in the thermal camera.



2006/66/EC (battery directive): This product contains a battery that cannot be disposed of as unsorted municipal waste in the European Union. See the product documentation for specific battery information. The battery is marked with this symbol, which may include lettering to indicate cadmium (Cd), lead (Pb), or mercury (Hg). For proper recycling, return the battery to your supplier or to a designated collection point. For more information see: www.recyclethis.info



2012/19/EU (WEEE directive): Products marked with this symbol cannot be disposed of as unsorted municipal waste in the European Union. For proper recycling, return this product to your local supplier upon the purchase of equivalent new equipment, or dispose of it at designated collection points. For more information see: www.recyclethis.info

2.Product Introduction

2.1 Camera

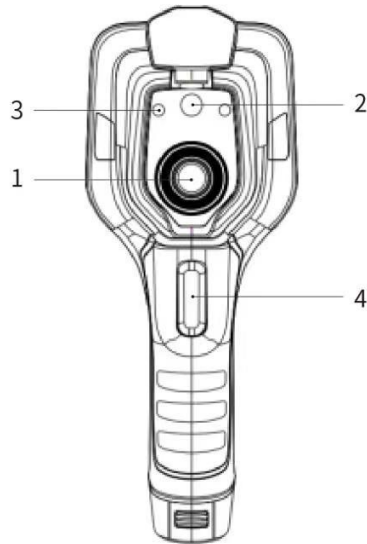

Table 2.1 Introduction to Camera Components (View from the front)

No.	Components
1	Infrared Lens
2	Digital Camera
3	Laser Pointer
4	Trigger

Note: the laser warning label is attached on the lens cap.



2.2 Buttons

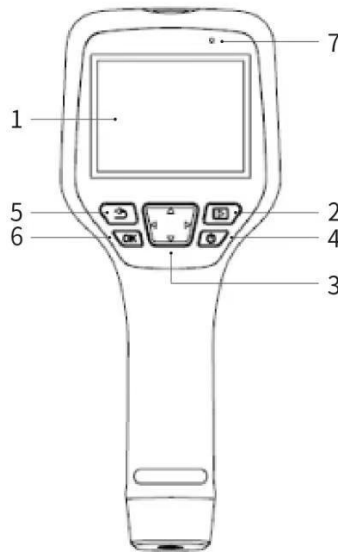

Table 2.2 Introduction to Buttons (View from the rear)

No.	Components	Function Description
1	Display screen	
2	Gallery button	Press to open the gallery. Long press to perform image uniformity correction.
3	Navigation button	Make selections for the menu, settings, gallery by clicking up/down/left/right.
4	Power/Laser button	Click to turn on/ Long press to turn off. When it is on, click to turn on/off the laser pointer.
5	Back button	Click to cancel the operation or return to the previous one. Long press to perform image uniformity correction.
6	Enter button	Click OK to confirm the operation.

2.3 Connector and Memory Card

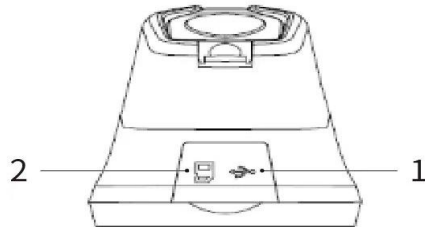

Table 2.3 Illustration of Connector and Memory Card

No.	Name	Description
1	USB Interface	<ul style="list-style-type: none"> ● Connect a USB cable with the power adapter for charging. ● Connect a USB cable to a computer to charge or transfer data.
2	SD Card	<ul style="list-style-type: none"> ● Standard MicroSD card, standard 32GB, Max 512GB ● The SD card can be taken out and transfer data to PC or other devices with a card reader.

3.Quick Start Guide

Please follow the procedures:

1.Charging

- Power adapter and USB cable can be used to charge the device.
- You can charge the device by connecting the USB cable in the accessory to the computer.

Note: This method of charging takes longer time than using the power adapter.

- Charging base can also be used to charge the battery.
- Please charge the device at room temperature.

2.Power on

Click the power button  to start the device.

3.Target Searching

Point the thermal camera at the object of interest.

4.Image Capturing

Click the trigger button to capture the image, and record the video by long pressing the trigger

button.

5.PC Software Analysis

Download the thermal camera client, launch the client, and use a USB cable or SD card to import data for secondary analysis.

6.APP analysis

Download the thermal camera client, launch the client, turn on the mobile device's WiFi, connect the mobile device to the hotspot of the OGI handheld camera, and import the data for secondary analysis.

4.User Interface



Figure 4.1 User Interface

Table 4.1 Interface Introduction

No.	Name	Description
1	Main Menu	Gas parameters, measurement parameters, measurement mode, image mode, color palettes and other settings can be set.
2	Sub Menu	Specific options can be set, such as a specific color palette.
3	Temperature measurement spot	Measurements of center spot, high/low temperature spot tracking, customize spot, customize line, customize area measurement are available.
4	Center spot temperature	The temperature of the center spot is displayed.

5	Date and time	date and time are displayed.
6	Battery capacity	The remaining battery capacity is displayed.
7	Temperature range	The temperature range in the current screen can be displayed.

5.Operation Instruction

5.1 Charging

5.1.1 Charge with a Power Adapter

1. Plug the power adapter into the socket.
2. Use a USB cable to connect the adapter and the camera to charge.

Note: It takes about 3h to get the device fully charged.

5.1.2 Charge with a Computer

1. Use a USB cable to connect the thermal camera to the computer to charge.

Note: when charging with a computer, the computer should be turned on, and the charging time is longer than using an adapter.

5.1.3 Charge with a Charging Base

1. Connect the power adapter and the charging base with a USB cable, and plug the power adapter into the socket.
2. Take out the battery and place it correctly in the charging base to charge.

Note: When the battery is not placed, the indicator of the charging base flashes; the indicator turns red when the battery is placed and charging; the indicator becomes green when the battery is fully charged.

5.2 Power On/Off

1. Click the power button to start the device.
2. Press the power button about 3 seconds to turn it off.

5.3 Focus Adjustment

Make sure that the device is powered on, align the camera at the measured scene, rotate the focus ring beside the lens clockwise or counterclockwise, which can make the image clearer via focal length adjustment, see the following figure for the detailed adjustment method:

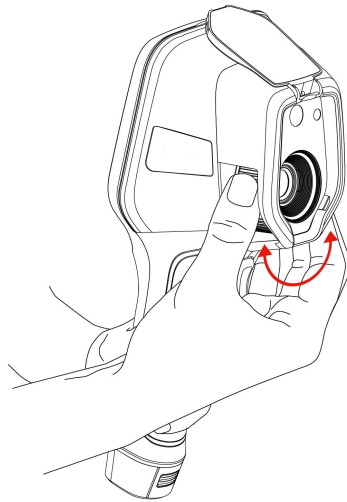



Figure 5.1 Focus Adjustment through Focus Ring

5.4 Image/Video Capture

1. In the observation interface, adjust the focus ring till the image is clear. Short press the trigger button to take the photo. Long press the trigger button to start recording video, release the trigger button to continue recording, and long press the trigger button again to stop recording.
2. Tap the save button on the touch screen or click the OK button or short press the trigger button to save the photos. Tap other buttons on the touch screen or use the navigation button + OK to scan the QR code to name the file, or cancel saving photos.

5.5 View Photos/Videos

The images you captured are saved in the SD card, and you can follow the below steps to view them at any time:

1. Enter the photo gallery by clicking gallery button.
2. Choose the image view modes by clicking the drop-down arrow , there are two kinds of modes: sort by filename or sort by time.

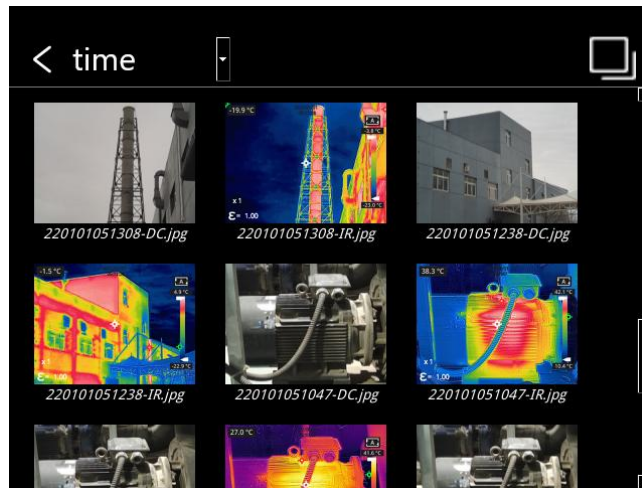

3. Select the picture or video you want to view by pressing the navigation button or touch screen.
4. Press OK or click the picture or video to view it in full screen. Select the delete option and then confirm to delete the current item. Select the rename option and confirm to rename the current item.

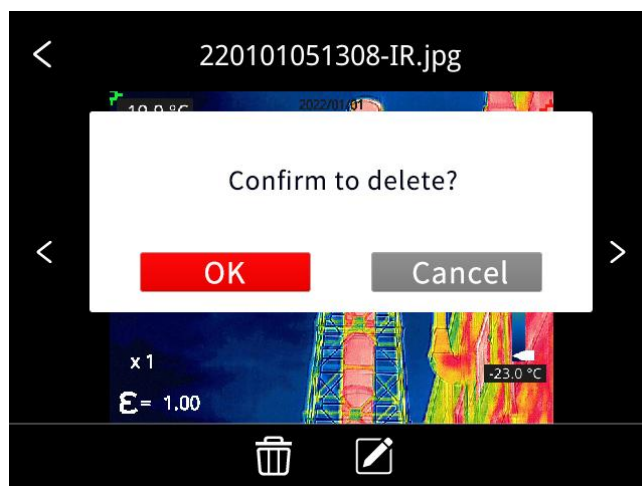

5. When in the preview interface, click the multiple button  in the upper right corner of the screen, then select the picture or video to be deleted, and delete the selected items by pressing the delete button.

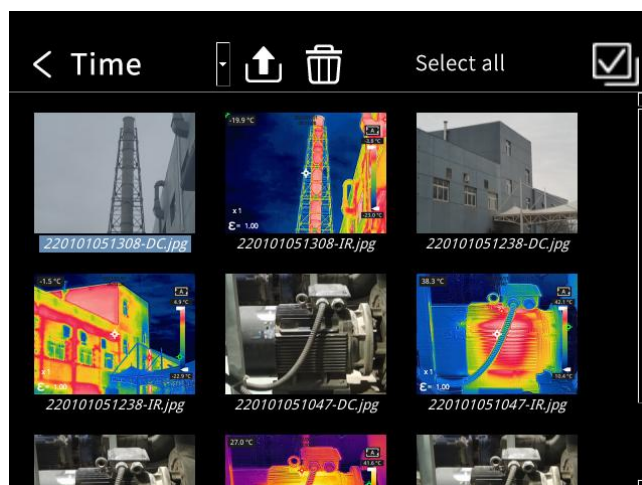

6. In the preview interface, tap the multi-select button  in the top right corner, then select the images and videos you want to upload. Press the upload button to send the selected items to the cloud server.

7. Single-click the gallery button, press the return button, or use the touchscreen to return to the observation interface.

5.6 Set Gas Detection Mode



On the observation interface, short press the OK button to show the main menu, and select the *Gas Detection Mode*  option, press the OK button again to show the sub menu, select On or Off by navigating left or right, then click the OK button to configure the parameters, click the OK button again to enable the function.

On the observation interface, click anywhere on the touch screen to show the main menu, click the *Gas Detection Mode*  option, click On or Off, click the image area to enable the function.

5.7 Measurement Parameters

In the observation interface, press OK to enter the main menu, use the navigation button to select the *Parameter Setting*  , then press OK again to enter the secondary menu. Select different temperature measurement parameters by shifting left or right, and press the enter button to parameterize. After setting, press OK again to save your option.

In the observation interface, click anywhere on the screen to enter the main menu. Click *Parameter Setting*  to set the parameter. After finishing the setting, click the screen area to take effect.

- **Emissivity**  : in order to obtain more accurate measurement results, you need to set the emissivity according to the target to be measured before each measurement, instead of using the default configuration. Emissivity refers to the ratio of the radiant ability of an object to the radiant ability of a blackbody at the same temperature, which is relative to the reflectivity of the object. The lower the emissivity, the higher the proportion of energy being reflected. The higher the emissivity, the lower the proportion of energy being reflected. For example, the emissivity of human skin is 0.98, and the emissivity of printed circuit boards is 0.91. For more information on emissivity, you can refer to the quick start guide in the package or inquire from other sources.
- **Ambient temperature**  : the reflection temperature of the object surface will affect the measurement result, especially when the object emissivity is low or the object temperature and the reflection temperature differ greatly, this effect will increase. So the result needs to be compensated to eliminate influences of the surface reflection temperature. However, it is usually difficult to

determine the reflected temperature of an object. The ambient temperature can be used to replace the reflected temperature in actual measurement.

- **Distance**  : distances have effects on the measurement results. In order to get accurate measurement, distance information of the object is necessary for the thermal camera to compensate the result.

5.8 Set Measurement Mode

In the observation interface, briefly press the OK button to bring up the main menu. Use the arrow buttons to select the "Measurement Settings"  option, and press the OK button to access the submenu. Use the navigation buttons to move left or right to select different measurement modes. Press the OK button to apply the selected mode.

In the observation interface, tap anywhere on the screen to bring up the main menu. Tap "Measurement Settings" , then select the desired measurement mode, and tap the screen area to apply the selection.

5.9 Image Mode

5.9.1 Image Mode Introduction

Five image modes are available.

- **DDE**: An infrared image with enhanced object edge details.

Note: this function is unavailable for some models.

- **Infrared**: infrared image.
- **Visible**: visible image.
- **PIP**: infrared image superimposed at the center of the visible image
- **Thermal Fusion**: an image fused to a certain scale between an infrared image and a visible image

Note: For better dual-light image effects, when in PIP or thermal fusion modes, you need to set the actual distance, that is, the approximate distance from the thermal camera to the object. If the preset registration parameters cannot meet the requirements, you can also manually perform fusion registration in the settings.

5.9.2 Setting Steps

In the observation interface, press OK shortly to enter the main menu, and select image mode  through the navigation button. Then press OK again to enter the secondary menu, there different image mode can be selected by shifting left or right on the navigation button. Save your option by pressing enter button.

In the observation interface, click any place on the screen to enter the main menu. Click *image mode*  and select the desired image mode, and then click on the screen area. The option is saved.

5.10 Change Color Palettes

In the observation interface, briefly press the OK button to bring up the main menu. Use the arrow buttons to select the "Color Palettes Settings"  option, and press the OK button to access the submenu. Use the navigation buttons to move left or right to choose different Color Palettes options. Press the OK button to apply the selected color palettes.



In the observation interface, tap anywhere on the screen to bring up the main menu. Tap "Color Palettes Settings" , then select the desired Color Palettes, and tap the screen area to apply the selection.

5.11 Non-uniformity Correction

5.11.1 Non-uniformity Correction Introduction

Non-uniformity correction is used to compensate for non-uniformity of detector pixels or non-uniformity caused by other optical interference. When there are more noise in the image, non-uniformity correction is needed, which is common when the ambient temperature changes rapidly.

5.11.2 Non-uniformity Correction Operations

In the imaging interface, long press the back button  or the gallery button  to perform non-uniformity correction.

5.12 Contrast Adjustment

- In the observation interface, the contrast of the infrared image can be adjusted by sliding up and down the arrow button  on the temperature scale on the right side of the screen.

The default temperature scale is 24.2°C-34.6°C in the auto mode.

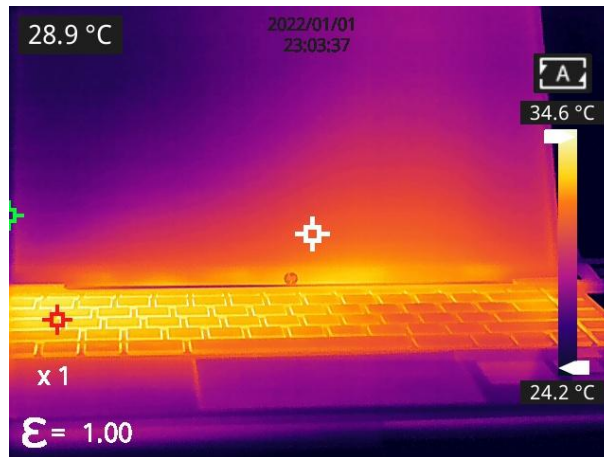

After the lower limit is changed to 27.7°C manually:

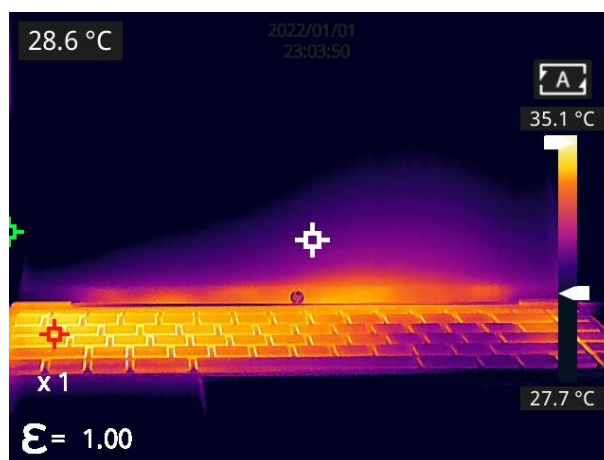

- Click the A button  in the bottom right corner to return to the auto contrast mode, the upper limit and lower limit will adjust automatically according to the Min temperature and Max temperature on the image, and the image color will distribute based on the color of the temperature scale.

5.13 Digital Zoom

In observation interface, press the navigation button to perform Max. 8×digital zoom.

Note: this function is only enabled under infrared mode or visible mode.

5.14 Other Settings

Other settings include date and time, unit, language and other items.

1) In the observation interface, short press the OK button to enter the main menu, and select *Settings*

 via the navigation button, then press the OK button to enter other settings.

2) In the observation interface, tap anywhere on the screen to enter the main menu, and tap *Settings*  to enter other settings.

5.14.1 Temperature Measurement Mode

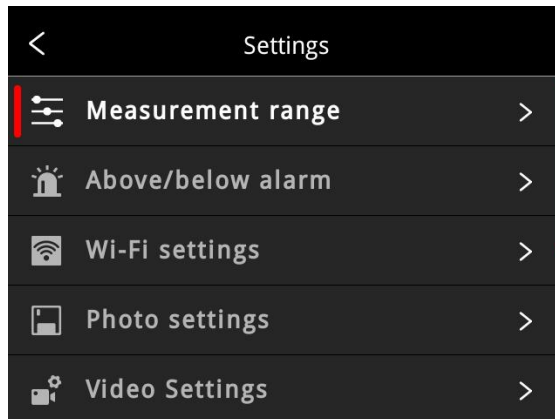

- -20~120℃ : the device supports thermal imaging between -20℃ and 120℃.

5.14.2 Above/Below Temperature Alarm

1.High temperature alarm switch: click to enable or disable the function of high temperature alarm.

Temperature setting for high temperature alarm: click on the pop-up keyboard and set the alarm temperature, 120℃ by default.

2.Low temperature alarm switch: click to enable or disable the function of low temperature alarm. Function.

Temperature setting for low temperature alarm: click on the pop-up keyboard and set the alarm temperature, 0℃ by default.

- Auto Alarm Snapshot: click to enable or disable, disable by default. Auto capture image during alarm.
- Time Interval: the time interval of alarm snapshot is 10s by default, click to perform custom setup.
- Number of Snapshot: 100 by default, click to perform custom setup.

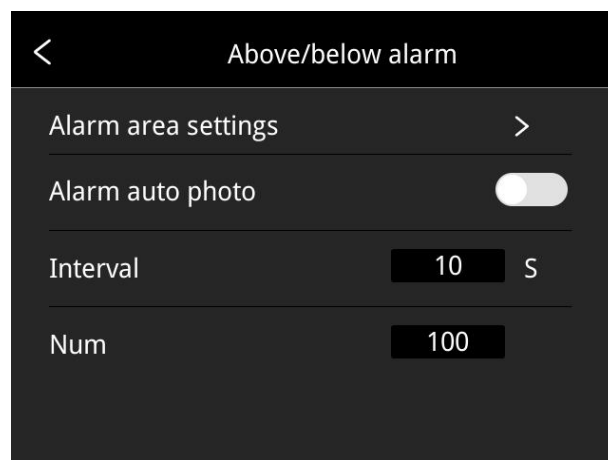

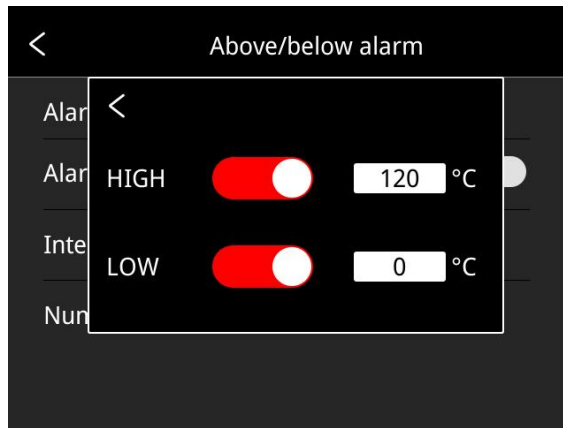

5.14.3 Wi-Fi Settings

Click and enter Wi-Fi settings interface.

- Hotspot Switch: turn on hotspot and set the network name and password, then click OK.

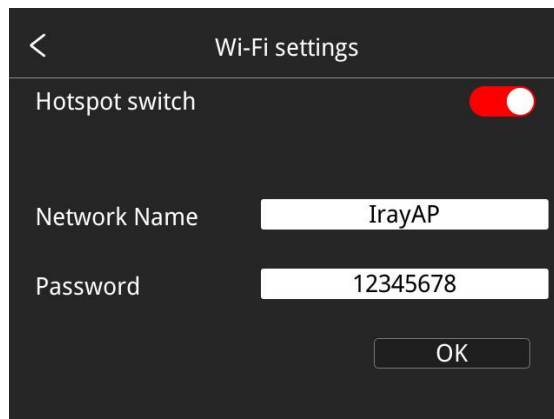

Note:

1)The specialized app is needed while this function is enabled. You need connect the hotspot manually after turning hotspot on, and you can transmit the saved pictures or videos to mobile device to perform secondary analysis.

2)Turn off hotspot when it is not used, or else the power consumption will be faster.

5.14.4 Photo Settings

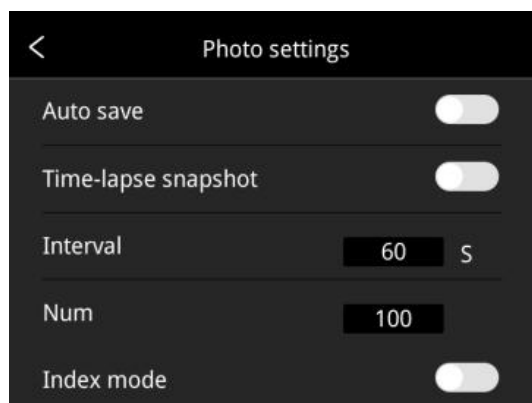

- Auto save of manual snapshot switch: click to enable or disable the function of auto save of manual snapshot, disabled by default.
- Time-lapse snapshot: click to enable or disable the function of time-lapse snapshot.
- Time interval of time-lapse snapshot: 60s by default, click to perform custom setup.
- Number of time-lapse snapshots: 100 by default, click to perform custom settings.
- Index mode: the file name is Time_Index_DC/IR.jpg by default if the index mode is enabled; the file name is Time_DC/IR.jpg if the index mode is disabled.

5.14.5 Dual-spectrum Alignment

- **Dual-spectrum Fusion Alignment**

This function can be used to manually register infrared and visible images. First select coarse tuning and fine tuning, and then perform image alignment through navigation buttons. After finished, click OK or enter button to save the settings. (You can drag on the touch screen with one finger to achieve fusion alignment in dual-spectrum fusion mode).

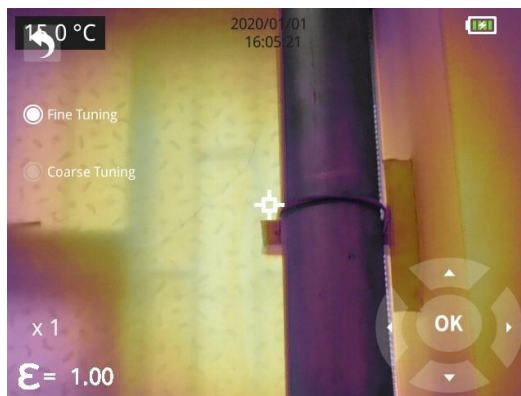

- **PIP Adjustment**

This function can be used to adjust the position of the picture-in-picture. First select coarse tuning and fine tuning, and then adjust the position of the picture-in-picture by the navigation buttons. When finished, click OK or enter button to save the settings. (You can move the PIP by dragging the picture with your one finger, and adjust the PIP size by dragging the picture edges).

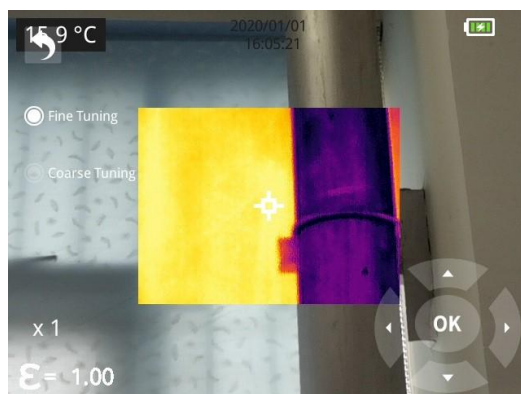

5.14.6 Automatic Power-off

- 5Min: click to perform auto shut down after 5 minutes.
- 10Min: click to perform auto shut down after 10 minutes.
- 20Min: click to perform auto shut down after 20 minutes.
- Off: Click to disable the function of auto shutdown, this function is disabled by default.

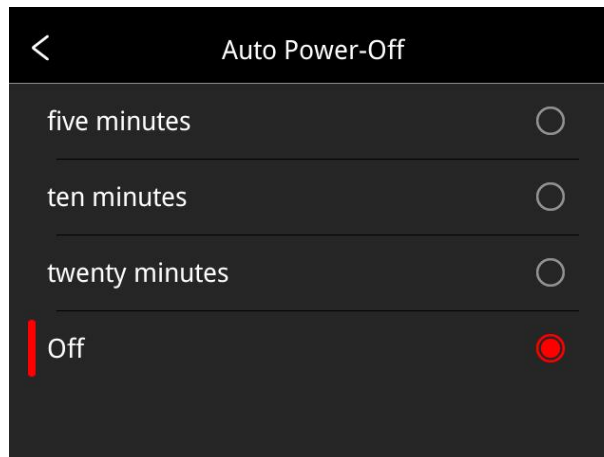

5.14.7 System Settings

1. Device Information

Click to check model, version, SD card capacity and SD card remaining capacity.

2. Date & Time

Click to perform date and time settings. The year can be self-defined from the Year 2020 to the Year 2037, the month, day, hour and min can be changed.

3. Unit

(1) Temperature Unit: switch between Celsius, Fahrenheit and Kelvin.

(2) Distance Unit: switch between meter and foot.

4. Screen Brightness

Click to perform date and time settings.

- High: click to set the screen brightness as high brightness.
- Medium: click to set the screen brightness as medium brightness, medium brightness by default.
- Low: click to set the screen brightness as low brightness.

5. Formatting the SD Card

Click and then press OK to format the SD card as FAT32.

6. USB Mode

There are two options for data transmission: U disk and USB camera.

- U disk mode: the saved images and videos can be read and analyzed when the camera is connected with other devices via a data cable in this mode.

- USB camera: the real-time image view and spot/line/region analysis can be achieved on the PC when the camera is connected with the PC via a data cable in this mode.

7. Restore Factory Settings

Click and then press OK, the camera will power off automatically a few seconds later, the settings will restore to the factory default state after reboot.

8. Software Update

Download the latest software to Update file in SD memory, click Update from SD memory to update. The camera will power off automatically, the software will update to the latest version after reboot.

6. Technical Specifications

6.1 RG600F

Technical Specifications		G600F
Thermal	Detector Type	Uncooled VOx infrared detector
	Detector Resolution	640x512
	Spectral Range	Central wavelength 10.55μm
	Pixel Pitch	12μm
	Focal Length	19mm
	FOV	23°x18°
	Focus Mode	Manual focus
	Temperature Measurement Range	-20 °C- 120 °C
	Temperature Measurement Accuracy	±2% or ±2°C, the larger value shall prevail
Camera Function	Temperature Measurement Mode	Center spot/hot and cold spot tracing and temperature display
	Spots, Lines and Areas Measurement	Movable spot/line/area temperature measurement; Line/area temperature measurement displays hotspot tracking; Line temperature measurement shows the maximum temperature, and area temperature measurement displays the Max, Min, and Avg values within the area.
	Color Palettes	10 types
	Temperature Alarm	An alarm is triggered if the highest or lowest temperature in the full frame exceeds the threshold.
	Alarm Type	Image Alarm
	Temperature Scale	Manual/Auto
	Laser Pointer	Yes

OGI Handheld Camera User Manual

Digital Camera	5MP
Digital Zoom	Max 8×
Video/Image Storage	Infrared .jpg image with temperature data + visible light .jpg image; Video without temperature data
Voice Annotation	Add voice annotations using the microphone
Language	Traditional Chinese, English, French, Spanish, Italian, Brazilian Portuguese, German, Polish, Korean, Hungarian, Turkish, Japanese.
Display	3.5-inch touch screen (480x640)
Image Naming	Automatic, manual, naming by scanning QR code
Memory Card	32GB MicroSD card
Battery Type	Rechargeable and removable Li-ion battery
Power Interface	USB Type C
Connectivity Type	USB, SD card, Wi-Fi (AP mode)
Power Management	Automatic shutdown: 5min, 10min, 20min or Off
Operating Temperature Range	-10 to +50°C
Storage Temperature Range	-20 to +60°C
Relative Humidity	10% ~ 95%, non-condensing
Dimensions (HxWxD)	256.4*105.1*105.3mm
Weight	About 670g
Tripod Mount	Yes
Gases Detectable	Sulfur hexafluoride Ammonia Ethylene Ethylene ether Vinyl chloride Trichloroethylene Methyl vinyl ketone Propylene Acrolein Acrylonitrile Ethyl cyanoacrylate Allyl fluoride Allyl chloride Allyl bromide Furan

6.2 RG600C

Technical Specifications		G600C
Thermal	Detector Type	Uncooled VOx infrared detector
	Detector Resolution	640x512
	Spectral Range	7.0-8.5μm
	Pixel Pitch	12μm
	Focal Length	19mm
	FOV	23°x18°
	Focus Mode	Manual focus
	Temperature Measurement Range	-20 °C- 120 °C
	Temperature Measurement Accuracy	±2% or ±2°C, the larger value shall prevail
Camera Function	Temperature Measurement Mode	Center spot/hot and cold spot tracing and temperature display
	Spots, Lines and Areas Measurement	Movable spot/line/area temperature measurement; Line/area temperature measurement displays hotspot tracking; Line temperature measurement shows the maximum temperature, and area temperature measurement displays the Max, Min, and Avg values within the area.
	Color Palettes	10 types
	Temperature Alarm	An alarm is triggered if the highest or lowest temperature in the full frame exceeds the threshold.
	Alarm Type	Image Alarm
	Temperature Scale	Manual/Auto
	Laser Pointer	Yes
	Digital Camera	5MP
	Digital Zoom	Max 8×
	Video/Image Storage	Infrared .jpg image with temperature data + visible light .jpg image; Video without data
	Language	Traditional Chinese, English, French, Spanish, Italian, Brazilian Portuguese, German, Polish, Korean, Hungarian, Turkish, Japanese.
	Display	3.5-inch touch screen (480x640)
	Image Naming	Automatic, manual, naming by scanning QR code
Memory Card	32GB MicroSD card	

OGI Handheld Camera User Manual

Battery Type	Rechargeable and removable Li-ion battery
Power Interface	USB Type C
Connectivity Type	USB, SD card, Wi-Fi (AP mode)
Power Management	Automatic shutdown: 5min, 10min, 20min or Off
Operating Temperature Range	-10 to +50°C
Storage Temperature Range	-20 to +60°C
Relative Humidity	10% ~95%, non-condensing
Dimensions	256.4*105.1*105.3mm
Weight	About 670g
Tripod Mount	Yes
Gases Detectable	<p>Methane Nitrous oxide Sulfur dioxide Phenol Ethyl acrylate 2-Ethylhexyl acrylate R13 R13B1 R123 R125 R134A R417A R422A R508A</p>

7. Dimensions

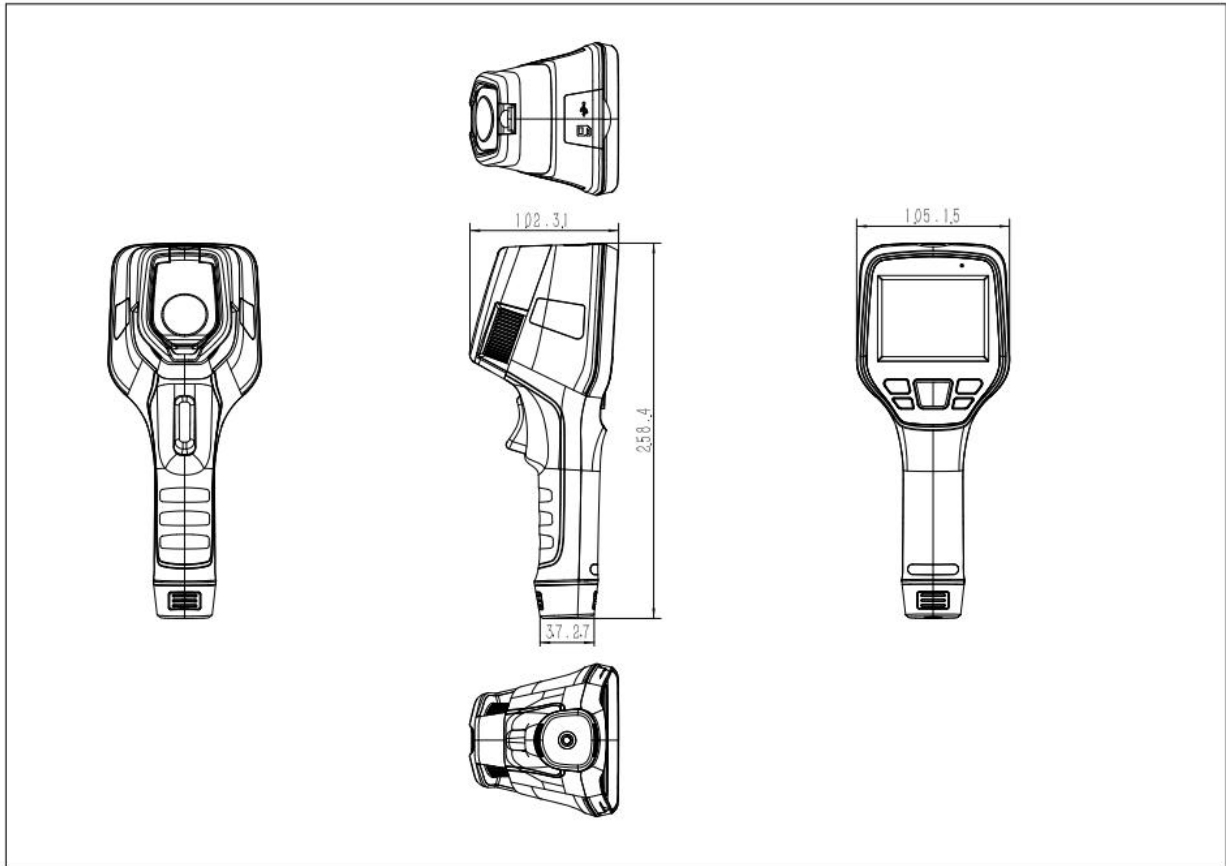

8.Cleaning Thermal Camera

8.1 Cleaning Camera Housing, Cables and Other Items

Camera Housing, Cables and Other Items	
Liquids	One of the following liquids can be used. 1.Warm water 2.A Weak detergent solution
Cleaning Tools	A soft cloth
Cleaning Procedure	Please follow this procedure: 1.Soak a soft cloth in the liquid. 2.Twist the cloth to remove excess liquid. 3.Clean the camera parts with the cloth.



CAUTION

Do not apply solvents or similar liquids to the camera, the cables, or other items. This can cause damage.

8.2 Cleaning Infrared Lens

Cleaning Infrared Lens	
Liquids	One of the following liquids can be used. 1.Commercial lens cleaning liquid with more than 30% is opropyl alcohol. 2. 96% ethyl alcohol(C ₂ H ₅ OH).
Cleaning Tools	cotton wool
Cleaning Procedure	Please follow this procedure: 1.Soak the cotton wool in the liquid. 2.Twist the cotton wool to remove the excess liquid. 3. Clean the lens one time only and discard the cotton wool.



CAUTION

Do not clean the infrared lens too vigorously. This can damage the anti-reflective coating.

Appendix A Emissivity of Commonly Used Materials

(1) Metal

Material	Temperature (°C)	Emissivity
Aluminum		
Polished aluminum	100	0.09
Commercial aluminum foil	100	0.09
Mild aluminum oxide	25~600	0.10~0.20
Strong aluminum oxide	25~600	0.30~0.40
Brass		
Brass mirror (highly polished)	28	0.03
Brass oxide	200~600	0.59~0.61
Chromium		
Polished chromium	40~1090	0.08~0.36
Copper		
Copper mirror	100	0.05
Strong copper oxide	25	0.078
Cuprous oxide	800~1100	0.66~0.54
Molten copper	1080~1280	0.16~0.13
Gold		
Gold mirror	230~630	0.02
Iron		
Polished cast iron	200	0.21
Machined cast iron	20	44
Completely rusted surface	20	0.69
Cast iron (oxidized at 600°C)	19~600	0.64~0.78
Electrolytic iron oxide	125~520	0.78~0.82
Iron oxide	500~1200	0.85~0.89
Iron plate	925~1120	0.87~0.95
Cast iron, heavy iron oxide	25	0.8
Melted surface	22	0.94
Melted cast iron	1300~1400	0.29
Pure molten iron	1515~1680	0.42~0.45
Steel		
Steel (oxidized at 600°C)		
Steel oxide	100	0.74

Material	Temperature (°C)	Emissivity
Melted mild steel	1600~1800	0.28
Molten steel	1500~1650	0.42~0.53
Lead		
Pure lead (non-oxidized)	125~225	0.06~0.08
Mildly oxidized	25~300	0.20~0.45
Magnesium		
Magnesium oxide	275~825	0.55~0.20
Mercury		
Mercury	0~100	0.09~0.12
Nickel		
Electroplating and polishing	25	0.05
Electroplating without polishing	20	0.01
Nickel wire	185~1010	0.09~0.19
Nickel plate (oxidized)	198~600	0.37~0.48
Nickel oxide	650~1255	0.59~0.86
Nickel alloy		
Nickel-chromium (heat resistant) alloy wire (bright)	50~1000	0.65~0.79
Nickel-chromium alloy	50~1040	0.64~0.76
Nickel-chromium (heat resistant)	50~500	0.95~0.98
Silver		
Polished silver	100	0.05
Stainless steel		
18/8 stainless steel	25	0.16
304 (8Cr, 18Ni)	215~490	0.44~0.36
310 (25Cr, 20Ni)	215~520	0.90~0.97
Tin		
Commercial tin plate	100	0.07
Zinc		
Oxidation at 400°C	400	0.01
Galvanized bright iron plate	28	0.23
Grey zinc oxide	25	0.28

(2) Non-metal

Material	Temperature (°C)	Emissivity
Brick	1100	0.75
Firebrick	1100	0.75
Graphite (lamp black)	96~225	0.95
Enamel (white)	18	0.9
Asphalt	0~200	0.85
Glass (surface)	23	0.94
Heat-resistant glass	200~540	0.85~0.95
Wall plaster	20	0.9
Oak	20	0.9
Carbon sheet	-	0.85
Insulating sheet	-	0.91~0.94
Metal sheet	-	0.88~0.90
Glass tube	-	0.9
Coil type	-	0.87
Enamel product	-	0.9
Enamel pattern	-	0.83~0.95
Capacitor		
Rotary type	-	0.30~0.34
Ceramic (bottle type)	-	0.9
Film	-	0.90~0.93
Mica	-	0.94~0.95
Flume type mica	-	0.90~0.93
Glass	-	0.91~0.92
Semiconductor		
Transistor (plastic package)	-	0.80~0.90
Transistor (metal)	-	0.30~0.40
Diode	-	0.89~0.90
Transmitting coil		
Pulse transmission	-	0.91~0.92
Flat chalk layer	-	0.88~0.93
Top ring	-	0.91~0.92

Material	Temperature (°C)	Emissivity
Electronic materials		
Epoxy glass plate	-	0.86
Epoxy phenol plate	-	0.8
Gold-plated copper sheet	-	0.3
Solder-coated copper	-	0.35
Tin-coated lead wire	-	0.28
Copper wire	-	0.87~0.88